

RoHS

REV	DESCRIPTION	MODIFICATION	DATE
A/0	新制定		06/09/02

*MATERIAL
 BODY : PBT30% UL 94V-0 RATED, COLOR: WHITE
 LATCH : PA66+30% UL 94V-0 RATED, COLOR: WHITE
 CONTACTS : BRASS
 CONTACT PLATING : GOLD PLATING OVER NICKEL ON CONTACT
 AREA TIN PLATING ON TERMINAL

*MECHANICAL
 MATING FORCE : 4.5 KG MAX. @ 25 MM/MINUTE
 UNMATING FORCE : 1.0 KG MIN. AND 4.0 KG MAX. @ 25 MM/MINUTE
 DURABILITY : 100 MATING CYCLES

*ELECTRICAL SPECIFICATION
 INSULATION RESISTANCE : 1000 MEGOHMS MIN
 DIELECTRIC WITHSTANDING VOLTAGE : 500 V DC RMS ±50 V, 60 HZ
 CURRENT RATING : 1.5 AMPERES MIN
 SHELL RESISTANCE : 50 MIILOHMS MAX, INITIAL;
 MAX CHANGE FROM INITIAL
 CONTACT RESISTANCE : 20 MIILOHMS MAX.

*ENVIRONMENTAL
 OPERATING TEMPERATURE : -20° TO 85°

*HOW TO ORDER
 PART NUMBER :

DF 240 R 1-4 2 2 01 B2

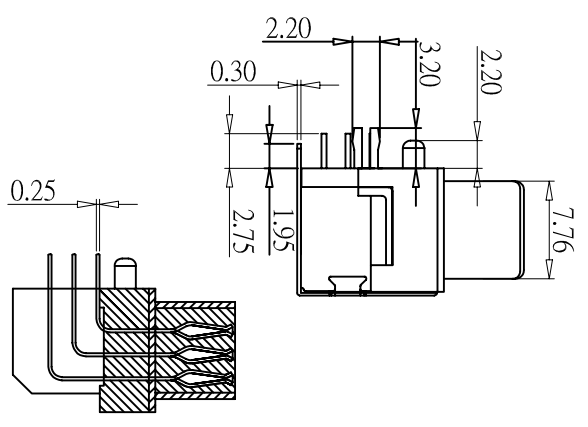

DVI板端母頭
 PIN數 24+0
 R : 90度
 "1":普通一般鐵殼
 "2":鍍全鍍
 "3":鍍全鍍
 "4":普通板前鐵殼+巨鐵殼防EMI型

省略: 沒有螺絲
 A*: 銅線螺絲 "A": 螺絲規格 1-(5.8*13.0) 2-(4.75*11.8)
 B*: 銅線螺絲 3-(5.8*9.5) 4-(4.75*8.5)
 01-1U

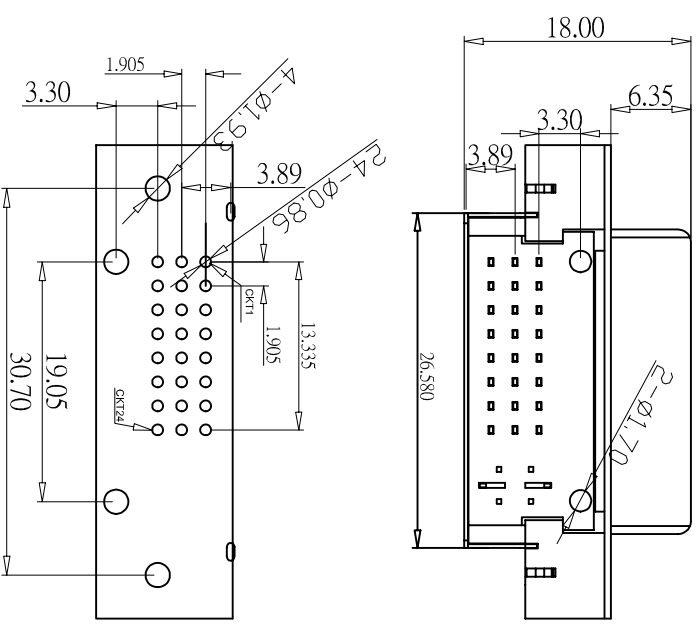

P.C.B LAYOUT

未標示公差尺寸值		DRAWN BY		FAN SHA	
METRIC .0=±0.35 .00=±0.25 .000=±0.15		CHECKED			
TITLE: DVI(24*01F90度)后包鐵殼 附4.75*11.80		APPROVED			
PRODUCT NO: DF240R1-42201B2		DRAW NO		COST-446	
FILE NO: ZK-3-D-001		UNIT		mm	
SCALE: 1:1		REV		A/0	